



# **Automated Lubrication System**

**Installation/Operator Instructions**

**John Deere STS Combine  
Models 9660, 9760, 9860**

Dtd.020405

# System Overview

Thank you for purchasing the Quicklub® On Board Grease System for your John Deere Combine.

The system has been designed to increase the component life and overall productivity of your equipment, while reducing labor costs related to the traditional method of point-by-point manual lubrication. The system consists of the Quicklub® progressive metering valves that positively displace and meter precise amounts up to N.L.G.I. #2 shop grease down to -13°F temperature. Grease is distributed to each connected point through high-pressure tube and hose.

This Quicklub® kit is designed to work with your John Deere STS Combine models 9660 and 9760 . There are subtle differences between models and years and this kit will accommodate all changes.

This is a fully automated lubrication system utilizing a 12 volt DC heavy duty electric pump with integrated timer that dispenses lubricant to the progressive metering valves at timed intervals. The lubricant is pumped to the primary metering valve, which distributes it to secondary metering valves in specific zones of service. The secondary metering valves deliver measured amounts of lubricant proportional to each lube point in its zone.

The components are connected with lengths of high-pressure hose and tubing that are included in the kit. Contents of the kit are specifically marked to coincide with this instruction manual to achieve a consistent and quality installation.

This manual has been included with the system as an easy-to-follow guide for installation and operation. Keep it with the equipment, as it is also a trouble-shooting manual to keep your automated lubrication system working properly.

This kit also contains Installation and Operation Instructions for the QLS 401 system supply pump. Please refer to this manual for detailed information on operations, maintenance, trouble shooting and technical data. If missing, please contact Lincoln and request service pace Q3-9, form #402865.

Durable and reliable, the Quicklub® On Board Grease System has been carefully designed using industry proven products to provide long and trouble-free life under the most severe farming conditions.

For further information on this system please contact Lincoln Technical Services at 1-314-679-4200 ext. 4782# or fax 1-314-679-4357.

THIS DOCUMENT (INSTALLATION INSTRUCTIONS) IS THE EXCLUSIVE PROPERTY OF LINCOLN INDUSTRIAL CORPORATION ('LINCOLN'). IT CONTAINS PROPRIETARY DATA AND INFORMATION DEVELOPED AT LINCOLN'S EXPENSE AND IS FURNISHED UPON THE EXPRESS CONDITION, ACKNOWLEDGED BY THE RECIPIENT, THAT IT'S CONTENTS SHALL NOT BE DISCLOSED, COPIED OR DUPLICATED, DISSEMINATED, OR USED, EXCEPT FOR THE PURPOSES ESTABLISHED BY WRITTEN CONTRACT OR OTHERWISE AUTHORIZED BY LINCOLN IN WRITING. LINCOLN RESERVES ALL RIGHTS UNDER PATENT, COPYRIGHT, TRADE SECRET AND OTHER APPLICABLE LAWS.

## LIMITED WARRANTY

*The following warranty relates to material and workmanship defects for components supplied in this kit however, standard maintenance is required for upkeep and reliability. In addition standard hose & tube routing practices will be needed, as described in this installation manual, to assure proper performance.*

*The installed system must be inspected periodically to correct any chaffing, rubbing or binding of the supply and feed lines. Connections must also be checked to insure continuity. Key point, is that due to the environment these combines operate in, normal wear and maintenance will be required.*

LINCOLN warrants the equipment it supplies to be free from defects in material and workmanship for one (1) year following the date of purchase. If equipment proves to be defective during this warranty period it will be repaired or replaced, at Lincoln's discretion, without charge provided that factory authorized examination indicates the equipment to be defective. To obtain repair or replacement, you must ship the equipment, transportation charges prepaid, with proof of date of purchase to a Lincoln authorized Warranty and Service Center, within the one (1) year following the date of purchase.

This warranty is extended to the original retail purchaser only. It does not apply to equipment damaged from accident, overload, abuse, misuse, negligence, faulty installation or abrasive or corrosive materials, or to equipment repaired or altered by anyone not authorized by Lincoln to repair or alter the equipment. This warranty applies only to equipment installed and operated according to the recommendations of Lincoln or its authorized field personnel. No other express warranty applies. Any implied warranties applicable to equipment supplied by Lincoln, including the warranties of merchantability and fitness for a particular purpose, will last only for (1 ) year from the date of purchase. Some jurisdictions do not allow limitations on how long an implied warranty lasts, so the above limitation may not apply to you.

In no event shall Lincoln be liable for incidental or consequential damages. Lincoln's liability on any claim for loss or damage arising out the sale, resale or use of equipment it supplies shall in no event exceed the purchase price. Some jurisdictions do not allow the exclusion or limitation of incidental or consequential damages, so the above limitation or exclusion may not apply to you. This warranty gives you specific legal rights. You may also have other rights that vary by jurisdiction.

## THE HEART OF THE QUICKLUB SYSTEM:

At the heart of every Quicklub System is the metering valve or progressive distributor block, designed to positively meter the input of lubricant (oil up to NLGI #2 greases) out to the connected number of lubrication points irrespective of distance and back pressure. The inlet passageway is connected to all piston chambers at all times with only one piston free to move at any one time. With all pistons at the far right, lubricant from the inlet flows against the right end of piston A (fig. 1).

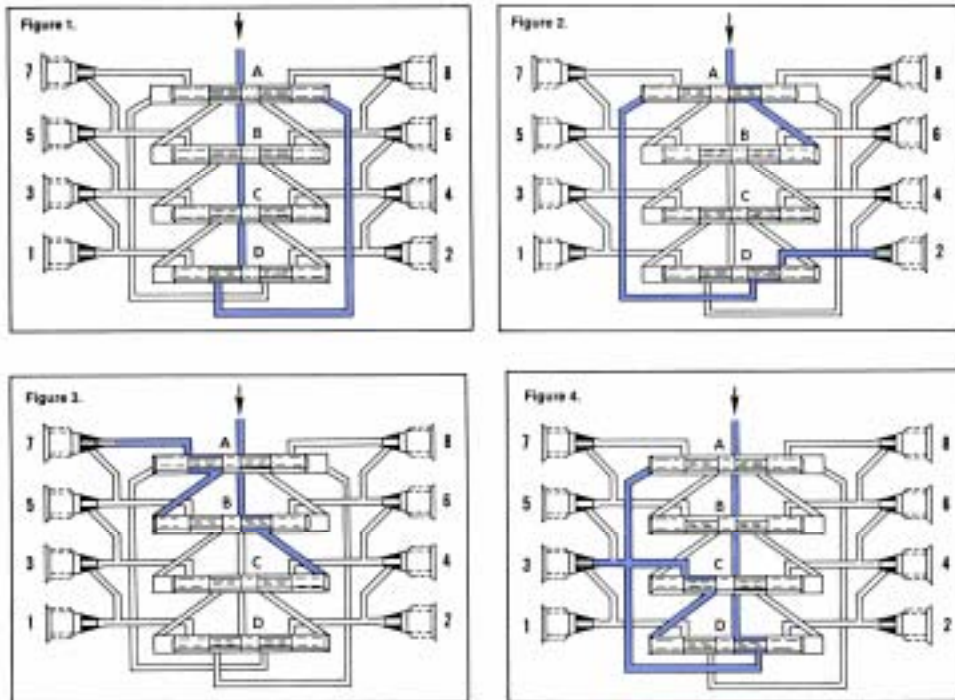

Lubricant flow shifts piston A from right to left, dispensing piston A output through Connecting passages to outlet 2. Piston A shift directs flow against right side of piston B (fig. 2).

Lubricant flow shifts piston B from right to left, dispensing piston B output through valve ports of piston A and through outlet 7 (fig. 3).

Lubricant flow shifts piston C from right to left dispensing piston C output through valve ports of piston B and through outlet 5. Piston C shift directs lubricant flow against right side of piston D (not illus.)

Lubricant flow shifts piston D from right to left, dispensing piston D output through valve ports of piston C and through outlet 3. Piston D shift directs lubricant through connecting passage to the left side of piston A (fig. 4).

Lubricant flow against left side of piston A begins the second half cycle which shifts pistons from left to right, dispensing lubricant through outlets 1, 8, 6 and 4 of the divider valve.

**Cross-porting (Divider Valve)**

Installing a closure plug in one or more outlets may combine outputs from adjacent outlets. Lubricant from a plugged outlet is redirected to the next adjacent outlet in descending numerical order.

**Outlets 1 and 2 must not be plugged since they have no cross-port passage to the next adjacent outlet.**

In figure 5 outlets 5 and 3 are cross-ported and directed through outlet 1. In this example, outlet 1 will dispense three times as much lubricant as outlet 7. The tube ferrules in outlets 1 and 7 block the cross-port passage so that lubricant flow is directed through the outlets.

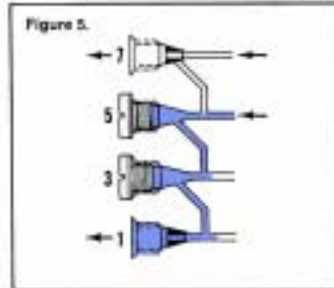









# Installation Steps:

The following steps will assist the installer with a systematic approach for installing the Quicklub Automated lube system on John Deere Combines. By following the steps outlined, a successful installation will be realized and will increase the service life of all pins and bearings connected to the lube system.

- Remove all grease fittings from lube points that will be connected to the lube system.
- Install appropriate adapters and tube fittings in lube points.
- Position valve mounting brackets to machine.
- Attach metering valves to previously mounted brackets.
- Use tubing cutters supplied, cut to length individual tubing feed lines from secondary valves to lube points and make connections.
- When installing feed line tubing into the Quickline fittings, push until firmly seated.
- Neatly bundle, loom with spiral wrap provided and tie strap feed lines wherever possible to protect from abrasion.
- Size, cut and attach appropriate hose ends to all supply lines. The high pressure hose is used as supply lines from the pump to the primary, the primary to the secondary. It is recommended that the supply lines be routed and cut only after all valves and the electric pump have been attached to the machine. This assures the supply line is cut to the proper length. Also, allow for unrestricted movement while the machine is in motion.
- Route supply lines from the pump to primary valve and from the primary valve to the secondary valve and make connections.
- Secure supply/feed lines with tie straps, so not in harms way. It is imperative to use normal professional routing standards to assure effective installation.
- Mount pump and make electrical connections (electrical diagram included with the pump).









## QUICKLUB COMPONENT GLOSSARY

### PART NUMBER and DESCRIPTION

	619-26398-2 - Divider valve SSV12 with indicator and 12 port outlets.....
	619-26844-1 - Divider valve SSV10 with indicator and 10 port outlets.....
	619-26396-2 - Divider valve SSV8 with indicator pin.....
	619-27121-1 - Divider valve SSV6 with indicator and 6 port outlets.....
	247023 - Grade 8 - 1/4" valve mounting bolt.....
	67448 - Male run tee.....
	404-22581-2 - Clamping ring (ferule).....
	239857 - Valve outlet adapter.....
	20028 - 1/8" NPT 45° Adapter.....

## QUICKLUB COMPONENT GLOSSARY

### PART NUMBER and DESCRIPTION

	244883	- 1/4" tube Quicklinc valve outlet fitting.....
	303-17489-3	- Valve closure plug for Black divider valves.....
	243899	- 90° Swivel quicklinc fitting.....
	20029	- 1/8" NPT 90° Adapter.....
	246416	- Valve mounting bracket.....
	51304	- 1/4" Nylon locknut for valve mounting.....
	51067	- 5/16" locknut.....
	242125	- Plastic Grease fitting cap.....
	246002	- 1/8" NPT field installable hose coupling.....



# QUICKLUB COMPONENT GLOSSARY

## PART NUMBER and DESCRIPTION



- 241286 - 1/8" Grease filled high pressure hose (26 ft. coil).....
- 241288 - 1/8" Grease filled high pressure hose (40 ft. coil).....



- 242025 - 1/4" grease filled black nylon tubing (25 ft coil).....
- 242050 - 1/4" grease filled black nylon tubing (50 ft coil).....



- 244054 - 1/4" -28 Male 90° Fitting.....



- 244066 - 1/4" -28 Male Straight Fitting.....



- 20024 - 2 1/4" -28 Straight Adapter.....



- 244047 - 1/4" Tubing x 1/8" NPT Male Straight.....



- 244048 - 1/4" Tubing x 1/8" NPT Male 90° Fitting.....



- 241054 - Nylon Ties (100 count poly bag) 7" Length.....

# QUICKLUB COMPONENT GLOSSARY

## PART NUMBER and DESCRIPTION



P40161202573 - QLS301 With Back Mounted SSV12 .....



241110 - Feed Line Bundling Spiral Wrap (10ft.) .....



5400 - 1/8" PTF Special Short 90° Fitting .....



244058 - 1/4 Tube X 1/4 Tube Splicer Union .....

The following lube points on your John Deere combine are not covered by this lubrication system as they are rotating. Please follow your John Deere supplied Operator's Manual for lubrication requirements and procedures for these specific lubrication points only.

<b>Points not covered by AutoLube on 9650 STS machines</b>			
<b>Description</b>	<b>freq. (hrs.)</b>	<b>O.M. Page No.</b>	<b>Illus. No.</b>
Feeder House Reverser Drive Gearcase (2 fittings)	50	115-6	3
Feeder House Upper Drive Sheaves (2 fittings)	50	115-6	2
Cleaninf Fan Variable Sheave (driver)	50	115-8	1
Cleaninf Fan Variable Sheave (driven)	50	115-8	2
STS Variable Speed Driven Sheave	200	115-11	1
STS Variable Speed Driver Sheave	200	115-11	2
STS Variable Speed Driver Sheave (plug)	400	115-14	-
Seperator Countershaft U-Joint Driveshaft slip-spline	400	115-16	1
Chopper/Unloading Driveshaft Bearing	400	115-16	2
*Spreader Disks (Both sides)	400	115-17	4
Tailings Drive Slip Clutch	400	115-18	2
Conveyor Auger Drive Slip Clutch	400	115-18	5
Upper Feederhouse Slip Clutch	400	115-24	6
*Omit if equipped with chopper			

## Right Side Grease Fittings

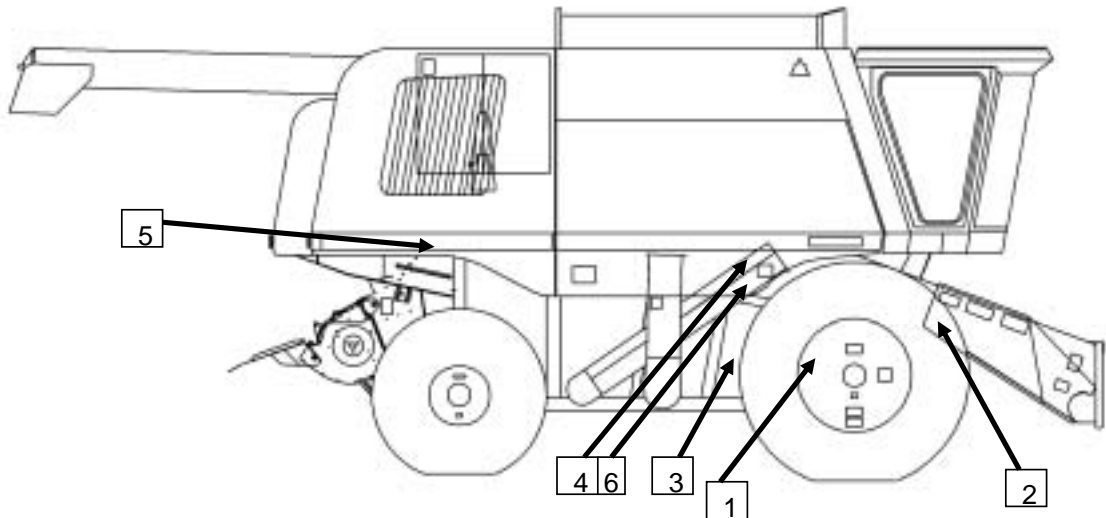

### Lube System Service Points

- |   |                              |
|---|------------------------------|
| 1 | Final Drive Outer Bearing    |
| 2 | Feed Accelerator Bearing     |
| 3 | Cleaning Fan Shaft Bearing   |
| 4 | STS Separator Bearing        |
| 5 | Discharge Beater             |
| 6 | Primary Countershaft Bearing |

# Right Side Secondary Valve

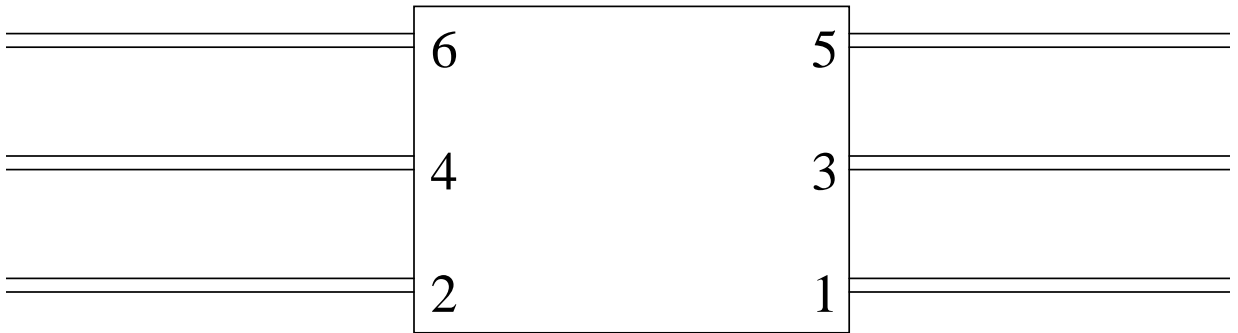

<u>Outlet #</u>	<u>Description</u>	<u>Tube Length</u>
1	Final Drive Outer Bearing	6 ft.
2	Feed Accelerator Bearing	7 ft.
3	Cleaning Fan Shaft Bearing	5 ft.
4	STS Separator Bearing	5 ft.
5	Discharge Beater	20 ft.
6	Primary Countershaft Bearing	6 ft.

## Right Grease Fittings



Mount Right Secondary Valve to the left of the Feed Accelerator Bearing as shown in the picture above. Use existing hardware for mounting valve bracket. Use spiral wrap to bundle/protect lines in both directions.



Install one # 243699, replacing grease zerk for Final Drive Outer Bearing. Route/install tubing to outlet 1. Use spiral wrap to bundle/protect lines in both directions



Install one # 244054 fitting, replacing grease zerk for Feed Accelerator Bearing. Rout/install tubing from outlet 2.



Install one 20026 adapter and one 244047 fitting, replacing grease zerk for Cleaning Fan Shaft Bearing. Route/install tubing from outlet 3.



Install one 244054 fitting, replacing grease zerk for S.T.S. Separator Bearing. Route/install tubing from outlet 4.



Install one 20024 adapter and one 243699 fitting, replacing grease zerk for Discharge Beater Bearing. Route/install tubing from outlet 5.



Install one 244055 fitting, replacing grease zerk for Primary Countershaft Bearing. Route/install tubing from outlet 6.



Use clamps, spiral wrap and ties that are supplied in the kit as needed to assure lines do not interfere with the operation of the combine.

## Left Side Grease Fittings

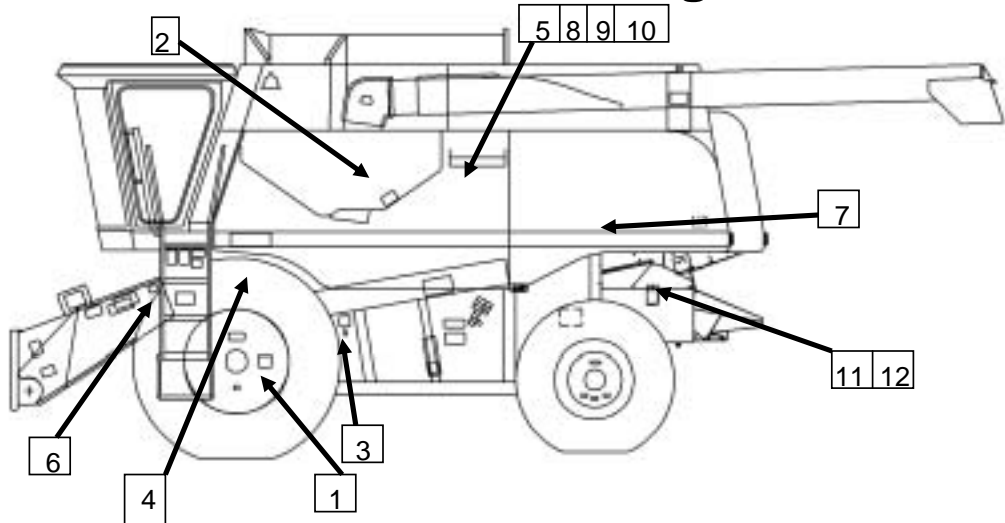

### Lube System Service Points

- |    |  |
|----|--|
| 1  | Final Drive Outer Bearing                |
| 2  | Unloader Auger Gear Case                 |
| 3  | Cleaning Fan Shaft Bearing               |
| 4  | Reel Drive Pump                          |
| 5  | Unloader Auger Upper Gear Case           |
| 6  | Feed Accelerator Bearing                 |
| 7  | Discharge Beater Bearing                 |
| 8  | Unloading Auger Swivel Joint             |
| 9  | Unloading Auger Swivel Joint             |
| 10 | Unloading Auger Swivel Joint             |
| 11 | Chopper & Discharge Beater Counter Shaft |
| 12 | Chopper & Discharge Beater Counter Shaft |



# Left Front Secondary Valve

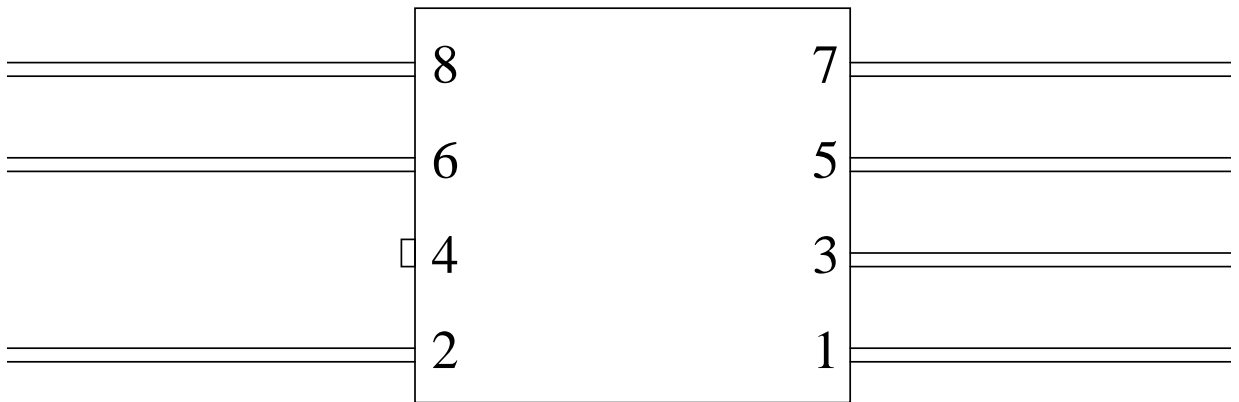

<u>Outlet #</u>	<u>Description</u>	<u>Tube Length</u>
1	Final Drive Outer Bearing	5 ft.
2	Unloader Auger Gear Case	10 ft.
3	Cleaning Fan Shaft Bearing	3 ft.
4	Plug	
5	Reel Drive Pump	5 ft.
6	Unloader Auger Upper Gear Case	8 ft.
7	Feed Accelerator Bearing	8 ft.
8	Discharge Beater Bearing	10 ft.

## Left Front Grease Fittings



Mount Left Front Secondary Valve below separator covers as shown in picture above. Use existing hardware for mounting valve bracket.



Install one 243699 fitting, replacing grease zerk for Final Drive Outer Bearing. Route/install tubing from outlet 1.



Install one 10181 and 20028 adapter and one 244048 fitting, replacing grease zerk for Unloader Auger Gear Case. Route/install tubing from outlet 2.



Install one 244055 fitting, replacing grease zerk for Cleaning Fan Shaft Bearing. Route/install tubing from outlet 3.



Install one 244054 fitting, replacing grease zerk for Reel Drive Pump. Route/install tubing from outlet 5.

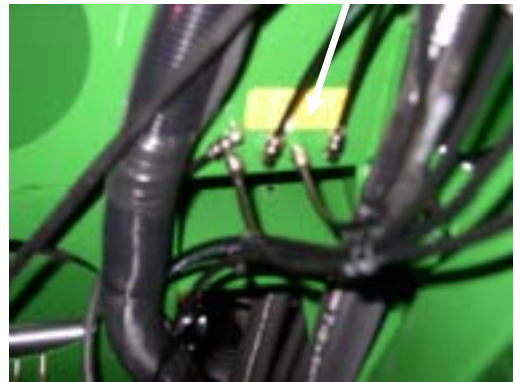

Install one 244054 fitting, replacing grease zerk for Unloader Auger Upper Gear Case. Route/install tubing from outlet 6.



Install one 244054 fitting, replacing grease zerk for Feed Accelerator Bearing. Route/install tubing from outlet 7.



Install one 244054 fitting, replacing grease zerk for Discharge Beater Bearing. Route/install tubing from outlet 8.

# Left Rear Secondary Valve

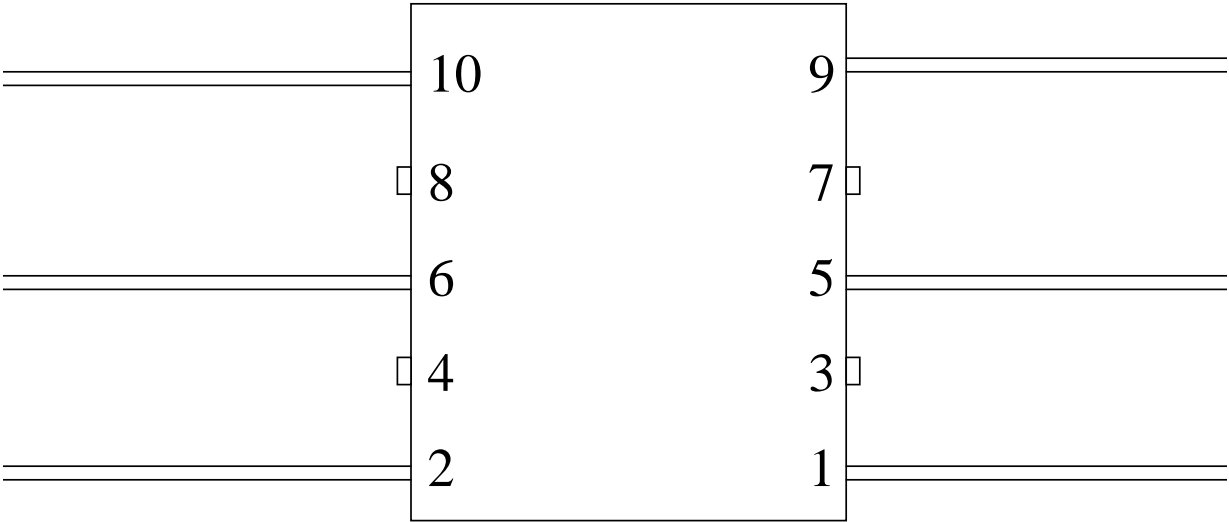

<u>Outlet #</u>	<u>Description</u>	<u>Tube Length</u>
1	Unloading Auger Swivel Joint	4 ft.
2	Unloading Auger Swivel Joint	2 ft.
3	Plug	
4	Plug	
5	Unloading Auger Swivel Joint	4 ft.
6	Unloading Auger Swivel Joint	4 ft.
7	Plug	
8	Plug	
9	Chopper & Discharge Beater Counter Shaft	11 ft.
10	Chopper & Discharge Beater Counter Shaft	11 ft..

## Left Rear Secondary Valve



Mount Left Rear Secondary Valve above separator covers as shown in the picture above. Use existing hardware on hose clamp for mounting valve bracket. Flip the hose clamp 180 deg. For clearance.

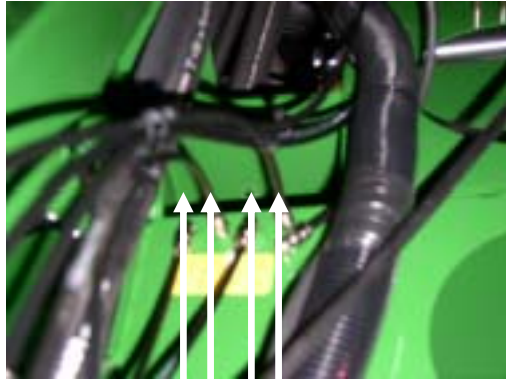

Install two 244054 fittings and two 244055 fittings, replacing grease zerk for Unloading Auger Swivel Joint (3 places). Route/install tubing from outlets 1, 2, 5 and 6.

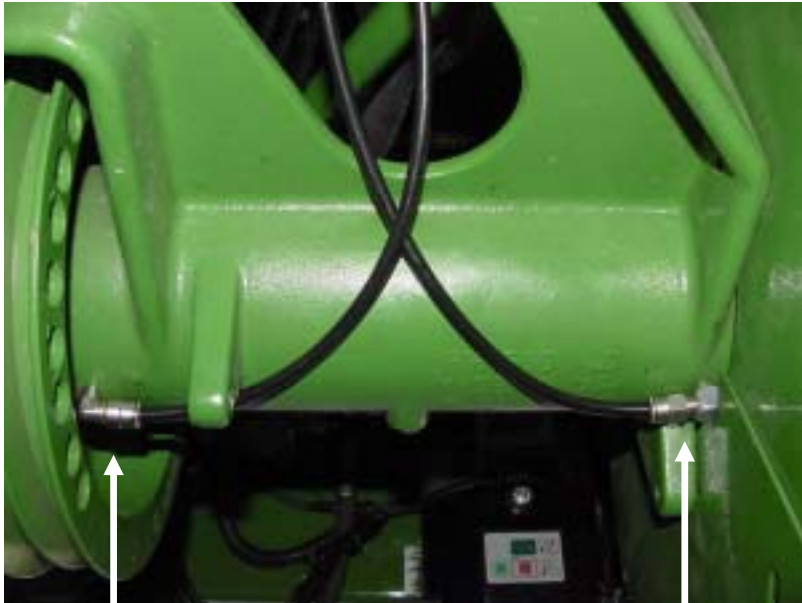

Install one 244054 fitting, replacing grease zerk for Chopper & Discharge Beater Counter Shaft. Route/install tubing from outlet 6.

Install one 20026 adapter and one 244047 fitting, replacing grease zerk for Chopper & Discharge Beater Counter Shaft. Route/install tubing from outlet 10.

# Rear End Grease Fittings

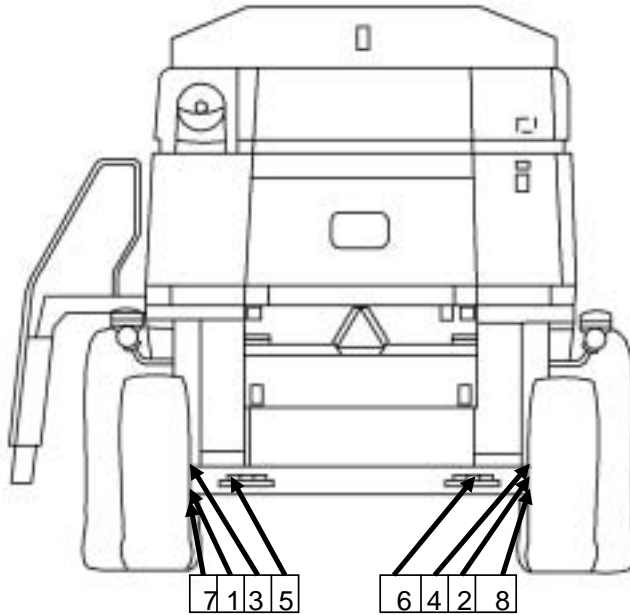

## Lube System Service Points

- 1 Lower Rear Axle Spindle - left
- 2 Lower Rear Axle Spindle - right
- 3 Upper Rear Axle Spindle - left
- 4 Upper Rear Axle Spindle - right
- 5 Rear Axle Spindle Bearing -left
- 6 Rear Axle Spindle Bearing - right
- 7 Power Steering Rod End Ball Joint - left
- 8 Power Steering Rod End Ball Joint - right

# Rear End Secondary Valve

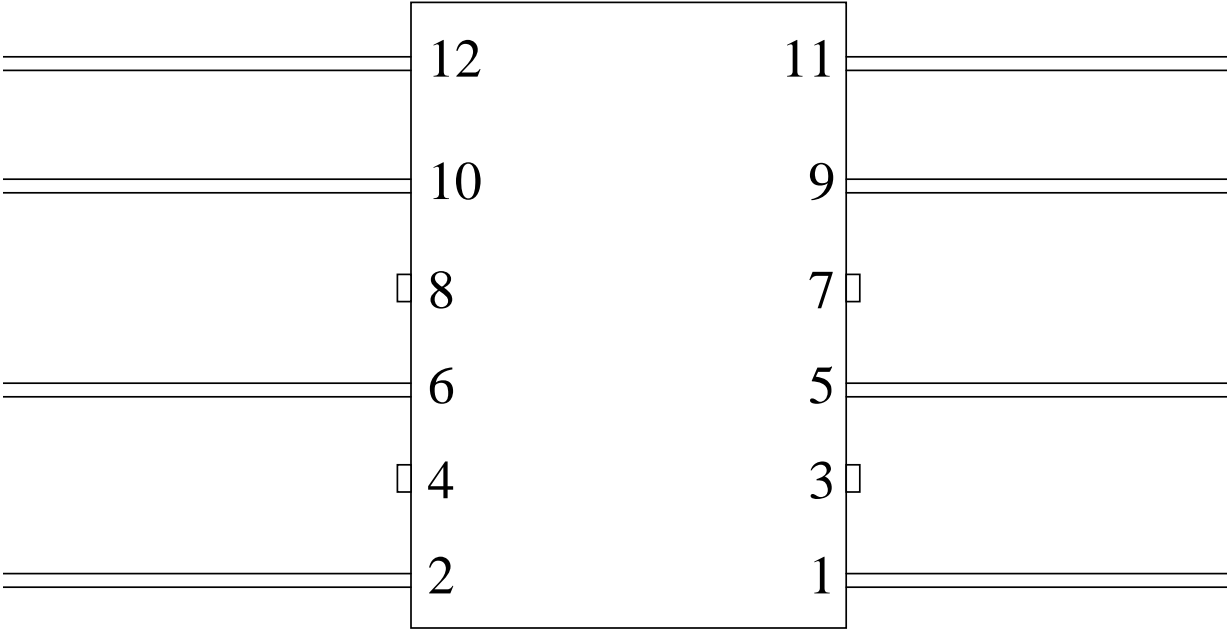

<u>Outlet #</u>	<u>Description</u>	<u>Tube Length</u>
1	Lower Rear Axle Spindle - Right	12 ft.
2	Lower Rear Axle Spindle - Left	10 ft.
3	Plug	
4	Plug	
5	Upper Rear Axle Spindle - Right	12 ft.
6	Upper Rear Axle Spindle - Left	10 ft.
7	Plug	
8	Plug	
9	* Rear Axle Spindle Bearing - Right	12 ft.
10	* Rear Axle Spindle Bearing - Left	10 ft.
11	Power Steering Rod End Ball Joint - Left	12 ft.
12	Power Steering Rod End Ball Joint - Right	6 ft.

\*For Powered Rear Axle – remove line and fitting from outlet 9 and 10 and replace with 303-17499-2 Plug.

## Rear End Valve

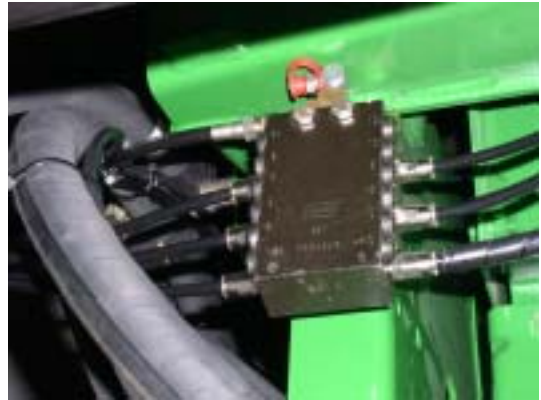

Mount Rear End Valve on the right rear of combine, directly above rear axle, as shown in picture above. Use existing hardware for mounting valve bracket. Note lines should be spiral wrapped where possible for protection. Outlets 11 and 12 may be removed and plugged with 303-17499-2 plug if required for combine rear end configuration.



Install one 243699 fitting (for powered rear axle, use one 20029 adapter and one 244047 fitting), replacing grease zerk for Lower Rear Axle Spindle – Right. Route/install tubing from outlet 1. Use 270931 clamp and existing hardware to attach bundle to knuckle casting.



Install one 243699 fitting (for powered rear axle, use one 20029 adapter and one 244047 fitting), , replacing grease zerk for Lower Rear Axle Spindle - Left. Route/install tubing from outlet 2. Use 270931 clamp and existing hardware to attach bundle to knuckle casting.





Install one 243699 fitting (for powered rear axle, use one 20029 adapter and one 244047 fitting), replacing grease zerk for Upper Rear Axle Spindle - Left. Route/install tubing from outlet 6.



Install one 243699 fitting (for powered rear axle, use one 20029 adapter and one 244047 fitting), replacing grease zerk for Upper Rear Axle Spindle - Right. Route/install tubing from outlet 7.



Install one 243699 fitting, replacing grease zerk for Rear Axle Spindle Bearing - Right. Route/install tubing from outlet 9.



Install one 243699 fitting, replacing grease zerk for Rear Axle Spindle Bearing - Left. Route/install tubing from outlet 10.

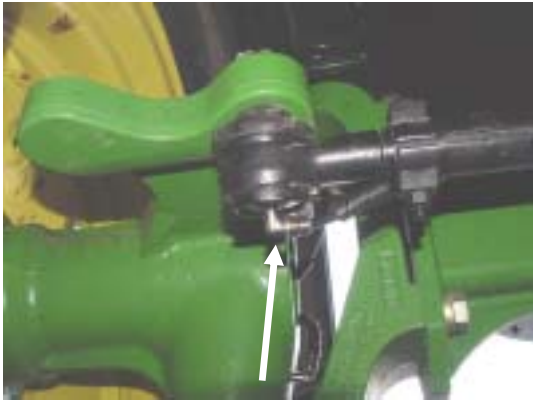

Install one 244054 fitting, replacing grease zerk for Power Steering Rod End Ball Joint. Route/install tubing from outlet 11.



Install one 244054 fitting, replacing grease zerk for Power Steering Rod End Ball Joint - Left. Route/install tubing from outlet 12.

# Primary Valve

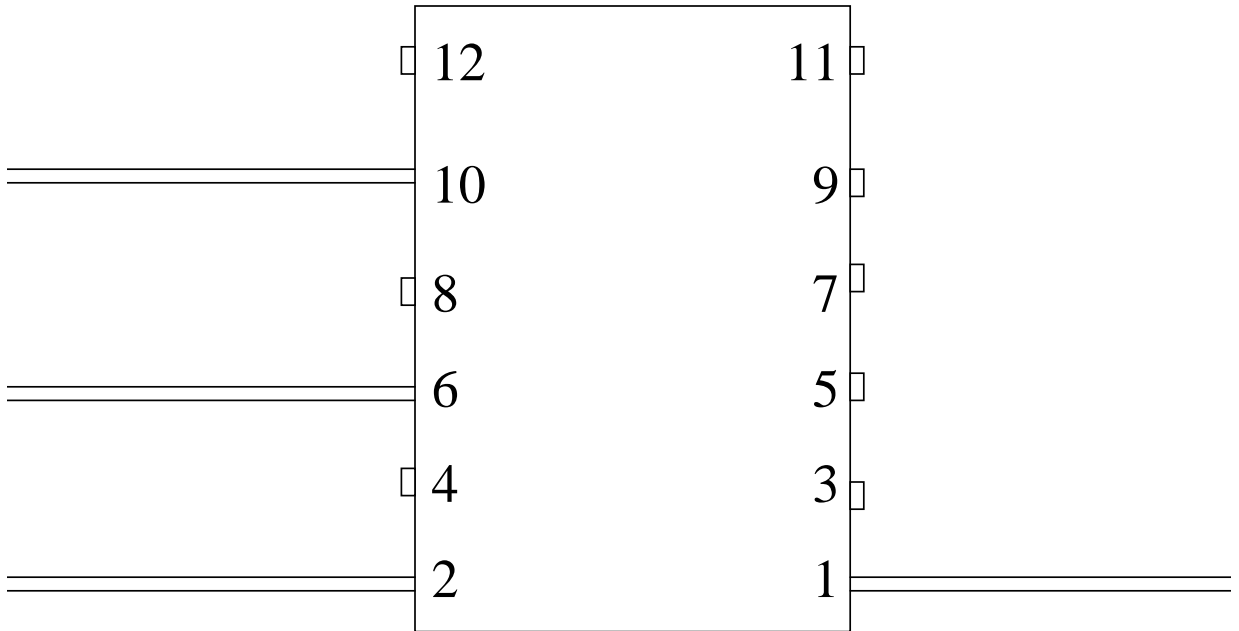

<u>Outlet #</u>	<u>Description</u>	<u>Hose Length</u>
1	Left Rear Secondary Valve	14 ft.
2	Rear End Secondary Valve	15 ft.
3	Plug	
4	Plug	
5	Plug	
6	Right Side Secondary Valve	30 ft
7	Plug	
8	Plug	
9	Plug	
10	Left Front Secondary Valve	20 ft.
11	Plug	
12	Plug	27

## Primary Valve



Install hose assemblies that feed the secondary valves into the primary valve located on the back of the QLS401 pump. Install hoses, by simply pushing the hose fitting into the valve fitting, using locations described on the drawing (previous page). Install one end first to the appropriate secondary valve. Route hose allowing for movement and servicing if necessary. Cut hose to the required length and install 246002 hose end. It is easier to install the hoses prior to mounting the pump.



Install hose from outlet 8 of primary valve to the inlet of Right Side Secondary Valve.



Install hose from outlet 7 of primary valve to the inlet of Left Front Secondary.

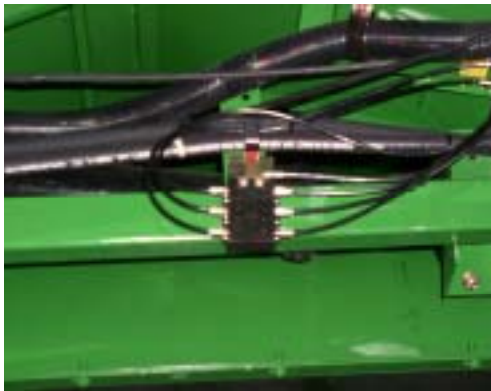

Install hose from outlet 1 of primary valve to the inlet of Left Rear Secondary Valve.



Install hose from outlet 2 of primary valve into the inlet of Rear End Secondary Valve.

## Mounting Pump



Install the 401 Pump to the rear right side of combine above the rear tire, as indicated above. To accomplish this you will need to use mounting bracket supplied. Secure with hardware supplied in pump box.



## Electrical Connections

*Safety note:* Be sure to disconnect the combine battery wires before proceeding with the electrical connections of this system.

Connect the black lead from the pump to the left hand main harness, circuit code 38 (red).

Connect the brown lead from the pump to local ground point using crimp on eyelet.

The red wire is not used.

# Programming the Pump

Recommended setting is for the pump to run one cycle every 20 minutes or 3 cycles/hour.

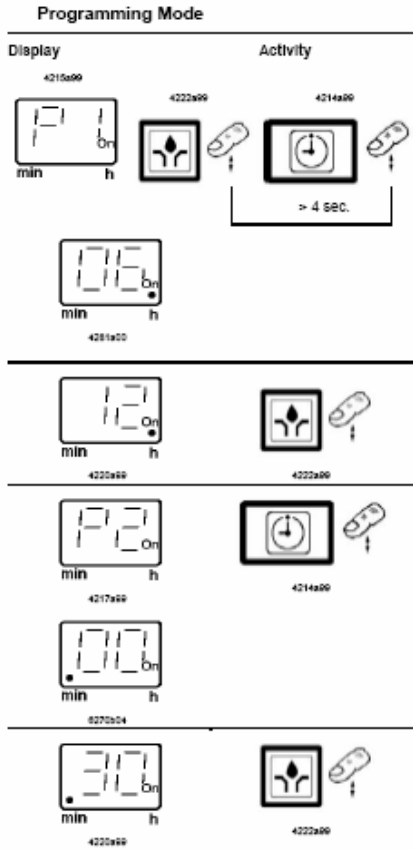
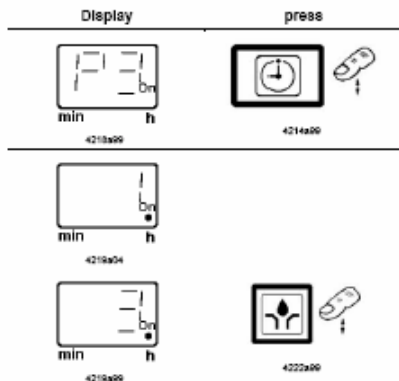

Fig. 31 Programming Mode (continuation next page)

**P3: Setting number of cycles**

If lube points are divided via sub-divider valves (SSV 6) and a main divider valve (SSV 6, SSV 8), a maximum of 18 (24) lube points must not be exceeded.



**Programming directions - Pause time (time between cycles):**

1. Power must be on to the pump
2. To access the programming mode, **press both buttons** at the same time for **4 seconds**.
3. After this is done, **P1 will flash** on the screen and a **number**.

This is the current **hour** setting of the controller.  
*P1 controls the hour setting (0 - 99 hrs.)*  
*P2 controls the minute setting (0 - 59 min.)*  
*Pause time- Min- 0 hrs. 20 min. Max- 99 hrs. 59 min.*  
*The fields "hour" and "minutes" are indicated by a decimal point on the right-hand for the hours, on*

*the left-hand for the minutes.*

4. Press the green button to set P1 (hours) to 0.  
 Settings are made in one direction: 0, 1, 2, 3, ..... 99 h  
 Button pressed once.....increases by 1 hour  
 Button pressed continuously.....quick sequence

5. Press the red button to set P2 (minutes).
6. Press the green button to set the time (minutes) to 20.  
 Settings are made in one direction: 0,1, 2, 3....59 min  
 Button pressed once.....increases by 1 minute  
 Button pressed continuously.....quick sequence

Note: If hours are set to zero, the minimum pause time begins with 20 minutes. When pause times < 20 minutes are programmed, the display automatically shows **.20**.

7. Press the red button to set P3 (number of cycles).
8. Press the green button to set number of cycles to 1. You have the option to set the number of cycles from 1 to 5.

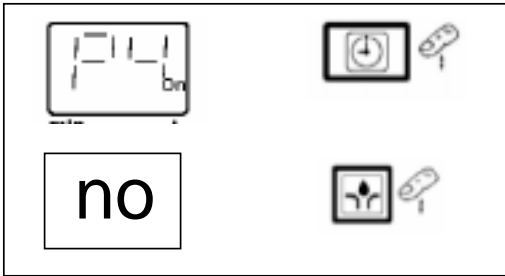

9. Press the red button to set P4 for output signal.
10. When releasing the button, the display “no” for normally open appears in the display.

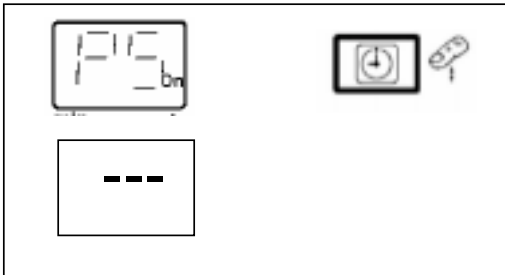

11. Press the red button to set P5 for fault indications.
12. When releasing the button, the display “- -” for permanent signal appears in the display.

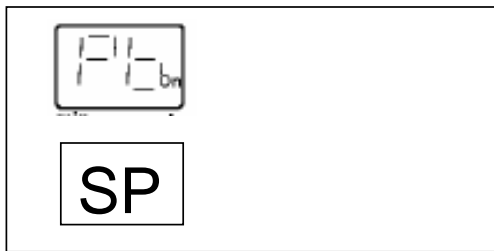

13. Press the red button to set P6 for starting/pause time.
14. Press the green button to read “SP”. This allows the timer to determine the status of run time when starting the pump. Another option is “SO”, which allows the pump to run every time the pump power is turned on.

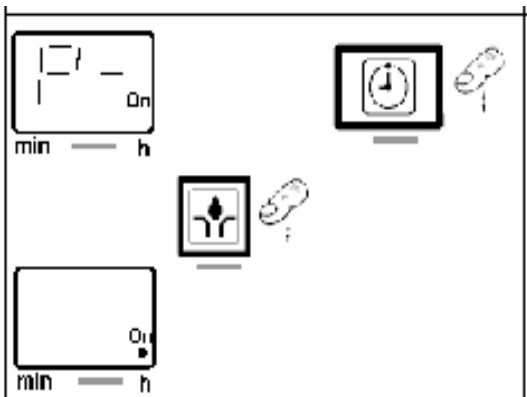

### Completing the programming

5. Press the red button. “P-” is displayed.
  - There are two ways to complete the programming:
    - by pressing the green button,
    - or
    - if the button is not pressed within 30 seconds, programming mode is closed automatically.

### Verifying the programming

8. Hold down the red button. In sequence:
  - PP The Programmed setting will be displayed.
  - RP The Remaining Time until a lube cycle will be displayed.



## System Checkout

The following checklist has been developed as an aid in verifying proper installation and operation of the Quicklub® Onboard Grease System. By completing the steps outlined below, the operational readiness of the system and resulting extension of the component life of all points connected to the system will be insured.

- Apply grease gun (manual or pneumatic) to the grease fitting located on the Primary valve and each secondary valve inlet. While pumping grease through the system, cycle the indicator pin on the primary metering valve a minimum of 15 times. NOTE: Grease gun nozzle and grease fitting should be thoroughly cleaned before lubricating to prevent flow of contaminants into the lube system.
- Inspect primary valve supply and outlets for grease discharge. If leakage is detected, tighten the fittings.
- Continue to cycle the system until fresh grease appears at each lube point.
- Inspect each lube point fitting for leaks. Correct any leaks by firmly pushing tube into the fitting until seating occurs, or tighten the threaded fittings for components connected with hose.
- Operate the equipment through its complete range of motion, inspecting for unrestricted movement of tube and hose. Correct any problems of rubbing, chaffing or kinking.
- Inspect all hose and tube that is not covered with some type of protective wrap. Wrap any tube or hose that would be susceptible to damage from rubbing or chaffing.
- Inspect all hose and tube connected to moving components. Insure that adequate hose or tube is provided to allow unrestricted movement to these moving lube points.
- Verify proper pump operation and verify time setting by activating pump with the green activation button located on the face of the pump control panel. Activate the pump at least three times to insure proper operation.
- After the Combine is in operation for a period of time (approx. 80 hours), you may find you need to adjust timing to a shorter or longer period based on the operating conditions.
- Fill the reservoir with selected grease by filling at the grease fitting located on the face of the pump reservoir.

## Daily Walk-Around Inspection

The Lincoln Industrial Quicklub automated lube system components are designed, engineered, manufactured and assembled to the highest quality standards. This lube system requires little maintenance, however, to ensure maximum reliability and to realize maximum service life of all components, it is highly recommended that a **daily walk-around inspection** be performed.

The daily walk-around inspection should include the following:

**NOTE: Operator to confirm operation of electric pump while machine is in service.**

- Observe lubricant level in reservoir. Fill reservoir if it is low.
- Inspect the display for error or low level messages. If panel indicates error, refer to the trouble shooting guide on next page.
- Inspect all valves and lube point connections to verify that no leaks are occurring.
- Inspect supply/feed lines to insure that no breaks or leaks have occurred.
- Inspect lube points so that all lube points have a **“fresh grease appearance.”**

## Troubleshooting

### Pump of the QLS 401 system

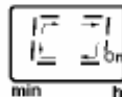

4259499

- The green rotating display indicates that the pump operates properly.

#### Fault: Pump motor doesn't run

##### Cause:

- Power supply interrupted. Green decimal point On/h on display is not lit.
- Power supply from printed circuit board to motor interrupted. Electric motor defective.
- Printed circuit board defective
- Keypad or button is defective. "EP" display at the keypad flashes.

##### Remedy:



4273600

##### WARNING!

*In case of pumps with 120 VAC and 230 VAC, disconnect the power supply before starting any maintenance or repair works.*

- Check the voltage supply to the pump/fuses. If necessary, eliminate the fault or replace the fuses.
- Check the feedline from the fuses to the plug of the pump and then to the printed circuit board.
- Trigger an additional lube cycle. Check voltage supply from the printed circuit board to the motor.
- Replace printed circuit board.
- Replace housing with keypad.

#### Fault: Pump does not deliver lubricant

##### Cause:

- Reservoir is almost empty. "Er" display at the keypad is flashing.
- Pump lost prime and "Er" display at the keypad is flashing.
- Air pockets in lubricant.
- Improper lubricant has been used.
- Suction hole of pump element clogged.
- Pump piston is worn.
- Check valve in pump element defective or clogged.

##### Remedy:

- Fill up the reservoir with clean grease. Let the pump run (initiate an additional lube cycle, see page 18) until lubricant shows at all lube points.



0001402

##### NOTE

*Dependent on the ambient temperature and/or sort of lubricant output. Therefore, trigger several additional lube cycles.*

- Trigger an additional lubrication cycle. Lubricant must dispense without air bubbles.
- Change the lubricant, see page 39.
- Remove pump element. Check suction hole for foreign particles. If there are any, remove them.
- Replace pump element.
- Replace pump element.

## Troubleshooting, continuation

**Fault: Pump either does not switch off at all or only after the monitoring time of 15 min.**

**Cause:**

- Proximity switch is not dampened, i.e. the control pin does not move within the switching range of the proximity switch, or the distance between the control pin and the proximity switch surface is more than 0.5 mm (0.02 in.).

**Remedy:**

- Trigger additional lubrication (see page 18). Check whether the control pin moves centrally over the switching surface of the initiator. In case the adjustments do not correspond to the indications, the fixing position of the metering device has to be corrected.
- Check the distance.
  - Between the control pin and the switching surface of the initiator (max. 0.5 mm; 0.02 in.)In case the adjustments do not correspond to the indications, the fixing position of the proximity switch has to be corrected.
  - Distances between the switching surface of the initiator and the upper edge of the fixing nut:  
When the divider block is mounted at the back: 16+ / -0.2 mm (0.62+/-0.08 in.)  
When the divider block is mounted at the bottom: 12,7 +/-0.1 mm (0.5 +/-0.004 in.).
- Tightening torque of the nut: 1,5 NM (1.10 ft-lb.).

**Fault: Pump runs continuously**

**Cause:**

- Programming of pause time in step P1 was set to '00'. Programming of further steps P2, P3 and P- was not carried out. Pump starts running immediately. The proximity switch switches off the cycle for two minutes. Then, pump runs continuously.

**Remedy:**

- Switch off pump (power supply) by removing left-hand socket from plug.
- Press both buttons of keypad:

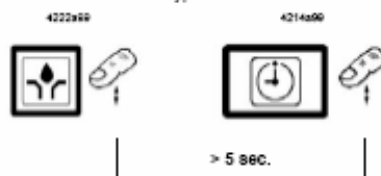

- Switch on pump (power supply) by replugging left-hand socket.
- Release both pushbuttons after five seconds.
- The factory-set pause time of 6 hours is automatically reset.
- Afterwards new setting of pause time is possible.

## Troubleshooting, continuation

### SSV divider block

#### Fault: Blockage in the downstream progressive system

##### Cause:

- Bearings, lines or divider block clogged
  - Mounting position of divider block : bottom
    - In the case of the divider block SSV 8,12 and 18 the outlet ports 1 and/or 2 are closed.
  - Mounting position of divider block : back-side
    - In the case of the divider block SSV 6, 12 and SSV 18 the outlet 1 is closed and outlet 2 is feed to a lube point.
- The fault can be identified as follows:  
a) Fault indication "Er" flashing on the keypad display.  
b) Fault indication "Er" flashing on the keypad piston does not move.

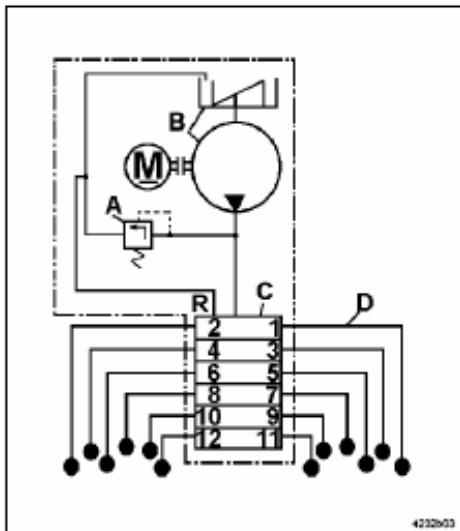

Fig. 34 Example of a QLS 401

- A pressure relief valve
- B pump
- C SSV 12 divider block
- D feedlines
- R return line

##### Remedy:

- Determine the cause of the blockage as described in the following example and eliminate it.
- ➔ Let the pump run (refer to "trigger an additional lube cycle", see page 18).
- ➔ Disconnect all feedlines (fig. 34, pos. D) of the divider block one after the other. If grease shows under pressure (i. e. at outlet 3) the blockage is located in the line of outlet 3 or in the connected bearing point.
- ➔ Pump through the blocked line or bearing point using a hand pump.



##### NOTE

To check the individual outlets, leave all outlets disconnected for a while, since only one piston stroke is executed with each motor revolution. Several strokes are required for a full cycle of all divider blocks.

- ➔ Check pressure relief valve (page 15, fig. 18). Replace it, if necessary.